

P-TYPE RINGERS

IDENTIFICATION AND MAINTENANCE

1. GENERAL

1.02 This section contains information for the P1A (MD), P1B (MD), P2B (MD), P3A, P3B, and P3C ringers (Fig. 1).

1.02 This section is reissued to:

- Add P3A, P3B, and P3C ringers
- Show P1A, P1B, and P2B ringers MD.

1.03 ♦The P3A, P3B, and P3C ringers are electrically identical and replace the P1A, P1B, and P2B ringers, respectively.♦

2. IDENTIFICATION

2.01 The P-type ringer is a single-coil, high impedance ringer mounted directly in a telephone set or by means of a 165- or 166-type adapter (Fig. 2). The 165-type adapter is equipped with a resonator (Fig. 3).

2.02 The P-type ringer has a variable mechanical volume control permitting adjustment from loud to low volume (Fig. 4).

Note: When the volume control is set in LOW position only ringer motor noise may be heard because clapper might not strike gong. If bell sound is desired, move control to slightly higher volume position.

2.03 The volume control can be moved to the cutoff position by rotating the dust cover until the openings line up with the access holes in the top of the gong and removing the factory placed stop screw (Fig. 3).



To avoid breaking the volume control arm when replacing stop screw, be sure volume control is in high volume position.

2.04 The coil of the P3A (Fig. 5) ringer has four spade-tipped leads and the early production models of the P1A have five spade-tipped leads to provide tip party identification. The P1B and P3B ringer coil is not tapped and has only two leads (Fig. 5). It can be used in any application not requiring tip-party identification.

2.05 ♦The P2B and P3C ringers are the same as the P1B and P3B ringers, respectively, except the leads are 16 inches long.♦

3. MAINTENANCE

3.01 The bias spring tension is a two-position control on the P-type ringer. The high tension notch or high bias position is with the bias spring engaged over the hooked end of the drive arm (Fig. 7). The low tension notch or low bias position is with the spring disengaged. The ringer is shipped from the factory with the bias spring in the low bias position. The correct bias spring tension for the high bias position has been factory-set to meet specific requirements.



Both ends of the drive arm (Fig. 7) are adjusted at the factory to meet correct clapper to gong spacing (drive end) and high bias spring tension (hooked end). Engagement and disengagement of the bias spring is the only recommended field change to this ringer. Do not use pliers or screwdriver to change bias spring position.

3.02 The correct procedure for changing bias spring position is as follows.

- (1) Bend a hook on the end of the paper clip or equivalent (Fig. 6).
- (2) Rotate dust cover until openings line up.

NOTICE

Not for use or disclosure outside the
Bell System except under written agreement

SECTION 501-259-101

(3) Place hook under bias spring as shown in Fig. 6. Lift spring up and release it for low bias setting or engage bias spring over hook on drive arm for high bias setting.

(4) Remove paper clip and rotate dust cover to its original position covering all openings.

3.03 Table A shows bias spring settings for class of service and number of ringing bridges required.

3.04 After positioning the bias spring, test ringer according to local instructions.

Note: When ring-back circuits are provided by the local central office, these facilities must be used instead of ring back from local test desk. The ringing voltage supplied from the local test desk may be higher and give false indications of proper operation.

3.05 If bell taps during dialing and bias spring is in low bias position.

- (a) Check ringer and set for proper wiring.
- (b) If wiring is correct, change bias spring to high bias position per paragraph 3.02.
- (c) Repeat ringer test.

3.06 If the ringer fails to operate, check that.

- Volume control is not in off position
- Gong is free of obstruction or foreign material.

3.07 If ringer continues to fail, replace ringer telephone set according to local instructions. If the ringer is replaced, a P3A ringer must be used if tip party identification or multiparty ringing is required. In all other applications either the P3A or P3B may be used.

3.08 For information on the maximum number of ringers that can be used for various services and loop lengths, refer to Section 500-114-100. For information relating to inductive noise associated with grounded ringing, refer to Section 500-112-100.

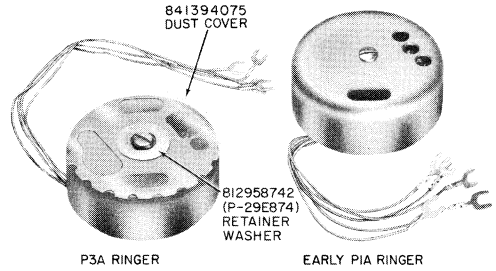

Fig. 1—P-Type Ringer

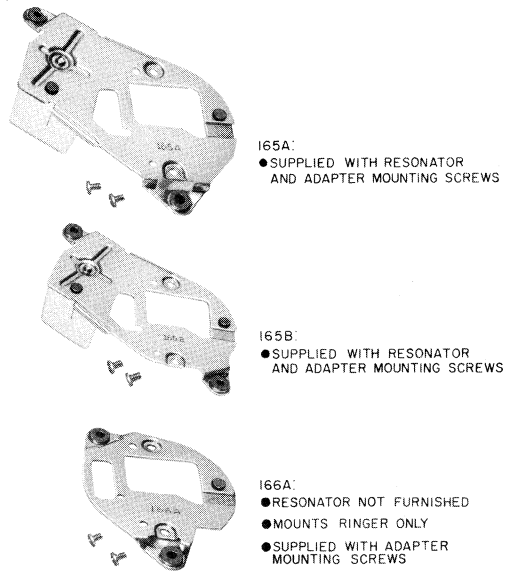

Fig. 2—P-Type Ringer Adapter Plates

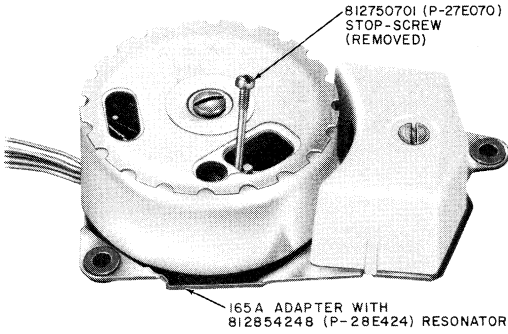

Fig. 3—P-Type Ringer Mounted on 165A Adapter

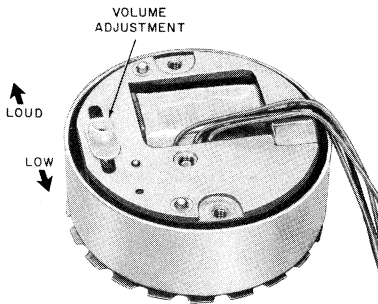
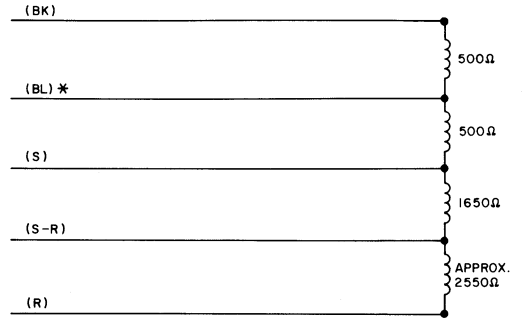
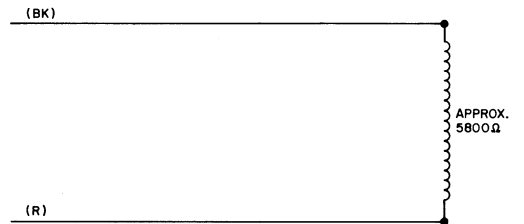

Fig. 4—P-Type Ringer (Bottom View)



A. PIA AND P3A RINGER

* (BL) LEAD WAS USED IN EARLY PRODUCTION PIA RINGERS



B. PIB P2B, P3B, AND P3C RINGER

Fig. 5—P-Type Ringer—Schematic

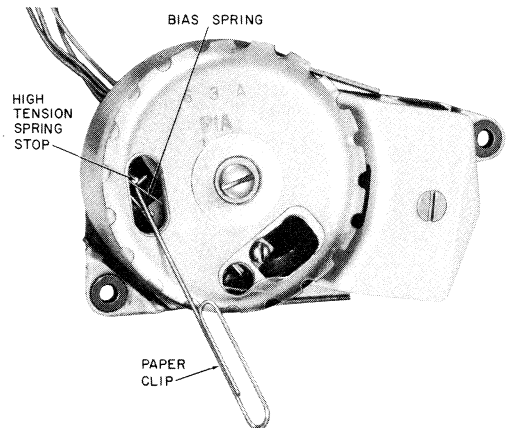

Fig. 6—Positioning Bias Spring

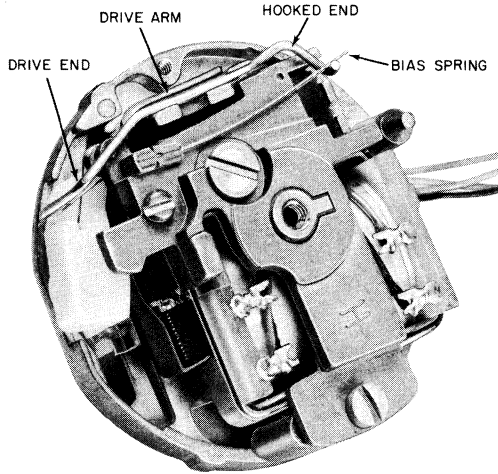

Fig. 7—Cover Removed to Show Drive Arm and Bias Spring

TABLE A

BIAS SPRING POSITION

SERVICE	BIAS POSITION
Bridge Ringing Individual Line (Note 1) Nonselective Party Lines PBX Stations	Low Low High
Grounded Ringing 2-party Flat and Message Rate (Note 2) 4-party Semiselective (Notes 2 and 3) 4-party Selective 8-party Semiselective Divided Code	High High Low Low Low

Notes:

1. When only a few (one or two) ringers are bridged across the line or the loop is short, bell tap may occur. To correct bell tap, change bias spring to high bias position.
2. Bias spring must be in high bias position on all two-party flat and message rate service and most four-party semiselective service (see Note 3) to prevent cross ringing (ringing of uncalled party when called party answers).
3. When five ringers are connected between same side of line and ground and operation is not satisfactory, bias spring may be placed in low bias position on all ringers on the same side of line. If condition is not corrected, change ringer.